

# ActivBoard+2 300 Range

## Product Specifications

### INTERACTIVE WHITEBOARD SYSTEM

The ActivBoard+2 is the consummate attention grabber with a state-of-the-art short-throw projector. From the audience, eyes can't help but face forward.

### ACTIVBOARD GENERAL SPECIFICATIONS

<b>Internal Resolution</b>	2730 points (lines) per inch
<b>Output Resolution</b>	200 points (lines) per inch
<b>Tracking Rate</b>	200 inches per second providing a fast response to pen commands
<b>Output Rate</b>	120 coordinate pairs per second
<b>User Input</b>	Cordless Battery-free pen incorporating tip switch and side switch for full mouse functionality (ActivPen)
<b>Digitizing Technology</b>	Passive Electromagnetic
<b>Power Requirement</b>	USB powered device
<b>Connection to Computer</b>	USB with supplied 5m (16ft) USB cable
<b>Screen Surface</b>	Low Glare Melamine
<b>Certifications</b>	UL, CE, FCC
<b>Upgrade Option</b>	Wireless connection to computer, dual user and integrated USB sound
<b>Packed Contents List</b>	ActivBoard, 2 ActivPens (Teacher), 5m (16ft) USB cable, 1 Amp PSU, Installation Guide, Access to ActivInspire Professional Edition via download from Promethean Planet



### ACTIVBOARD SPECIFICATIONS

Model	ActivBoard 378	ActivBoard 387	ActivBoard 395
ActivBoard Size	78in	87in	95in
Resolution	12800 x 9200	14600 x 9200	17200 x 9200
Screen Formats	4:3	16:10	16:9
Overall Dimensions	1868mm x 1329mm (73.5in x 52.3in)	2105mm x 1329mm (82.9in x 52.3in)	2412mm x 1329mm (95in x 52in)
Active Area Dimensions	1628mm x 1175mm (64in x 46in)	1865mm x 1175mm (73in x 46in)	2172mm x 1175mm (86in x 46in)
Active Area Diagonal	2000mm (78.7in)	2196mm (86.5in)	2462mm (96.9in)
Actual Image Diagonal	1958mm (77.1in)	2193mm (86.4in)	2397mm (94.4in)
Board Weight	26.5kg (58lb)	27kg (59.5lb)	34.5kg (76lb)
Packed Weight	42kg (93lb)	42.5kg (94lb)	50.5kg (111lb)

### MINIMUM COMPUTER REQUIREMENTS

Operating Systems	Windows XP SP2 and above (XP/Vista/7); Mac OSX 10.4.11 – 10.6.1 (Tiger/Leopard/Snow Leopard); Linux Ubuntu 8.04, 8.10, 9.04, 9.10; Mandriva
PC	Pentium 4 – 1 GHz processor (800MHz for Vista), 512 MB of RAM, 1024x768 resolution, 1.5 GB of Free Disk space
Mac	Macintosh Intel Processors (Universal Binary), 512 MB of RAM, 1024x768 resolution, 3.0 GB of Free Disk Space
Installation	ActivBoard+2 system requires installation by an certified Promethean installer. Components supplied and minimum specifications stated have been tested and are required for optimal performance. Use of components not supplied by Promethean or not meeting minimum specifications may impact performance and affect warranty. Contact your Promethean partner or visit <a href="http://www.prometheankb.com">www.prometheankb.com</a> for more information.

### ADJUSTABLE FRAME SPECIFICATIONS

<b>Board Size</b>	Accommodates ActivBoards 378 Pro, 387 Pro and 395 Pro
<b>Height Settings</b>	Height-adjustable mount, with 600mm (24in) of adjustment from 400mm (16in) to 1000mm (39in). Top limit stop is fitted if the full range of movement is not required/appropriate. Height adjustment is powered by an electrical motor and is operated by using a remote control unit attached to the stand.
<b>Projector Mount</b>	Aluminium arm, extends 1670mm (67.5in) from the wall, adjusts with the height of the Activboard reducing the need for specific re-calibration following height adjustment.
<b>Room Height Requirements</b>	Min. 2.68m (105.5") for full range operation
<b>Integrated Power Management</b>	For ActivBoard, Projector and Actuator
<b>Actuator</b>	<p>Input Voltage: 24VDC            Max Load: 750N            Static Load: more than 750N            Speed: 40mm/s (no load), 25mm/s (750N)            Stroke Length: 600 ± 2mm            Retracted Length: 795 ± 2mm            End Mounting Dimension: H Type, ø10.1 hole, 6.3mm Slot            Limit Switch: Built-in            Duty Cycle: S2-10min            Temperature: -26°- 65°C            IP Degree: IP54</p> <p><b>AC-DC Adaptor:</b>            Input Voltage: 100 ~ 240VAC            Output Voltage: 29VDC            Current: 2Amp (4Amp protected)            Cable and Plug: 1.5m, IEC Plug</p>
<b>Weight (approx.)</b>	Approx. 58kg (127.9lb) excl. board, projector and cabling
<b>Complete System Weight</b>	Approx. 88kg (194lb) (when ActivBoard 378 Pro fitted)
<b>Cable Kit Contents</b>	Connectivity box with inputs for 2 x PC inputs (VGA & Audio RCA), USB input, S-video and composite video, plus auxiliary audio RCA inputs. Box also has VGA switch for PC inputs and volume control for audio output cable. Box is mounted to the frame and can be placed on either side of the system. 2m (6ft) USB patch cable (to connect computer to face plate). 2m (6ft) 3.5mm Jack to RCA cable for PC audio input (to connect computer to face plate). 2m (6ft) VGA cable provided in the projector box (to connect the computer to the face plate).
<b>Pack Weights &amp; Dimensions</b>	<p><b>Box 1 of 4:</b> 24kg (53lb)            Dimensions: 2020mm x 300mm x 220mm (79.5in x 11.8in x 8.7in)            Contents: Extrusions and boom assembly</p> <p><b>Box 2 of 4:</b> 27kg (60lb)            Dimensions: 1270mm x 1000mm x 170mm (50in x 39.4in x 6.7in)            Contents: Projector plate and accessories</p> <p><b>Box 3 of 4:</b> 15kg (33lb)            Dimensions: 1170mm x 250mm x 180mm (46.1in x 9.8in x 7.1in)            Contents: Actuator cover and frame cables</p> <p><b>Box 4 of 4:</b> 2.6kg (5.7lb)            Dimensions: 360mm x 250mm x 170mm (14.2in x 9.8in x 6.7in)            Contents: Cable wall box</p>

### PROJECTOR SPECIFICATIONS

Model	PRM-30 (LCD)	PRM-35 (DLP)
Native Resolution	WXGA (1280 x 800)	WXGA (1280 x 800)
Compressed Resolution	up to 1080i	up to 1080i
Typical Colours	16.77 million colours	16.77 million colours
Brightness (ANSI lumens)	1900lm/1500lm/ 2500lm (normal/normal 2/high)	2100 ANSI (normal), 2500 ANSI (high)
Contrast Ratio	500:1	2000:1
Noise Level	29dB (normal), 36dB (high brightness mode)	32db (normal), 36db (high)
Dimensions (w x d x h)	382mm x 430mm x 129mm (15in x 16.9in x 5in)	306mm x 275mm x 97mm (12.0in x 3.8in x 10.1in)
Weight	5.7kg (12.5lb)	2.72kg (6lb)
Aspect Ratio	16:10 (native), 4:3, 16:9	16:10 (native), 4:3, 16:9
Power Consumption	317W (<0.8W standby)	230W (<1W standby)
Device Type	LCD technology	DLP Technology
Focus	Manual Focus	Manual Focus
Zoom	Digital Zoom	Digital Zoom
Focal Length	Fixed	Fixed
Projection Distance	0.54m ~ 1.22m (21.3in ~ 48in)	0.5m ~ 5m (19.7in ~ 169.9in)
Projection Screen Size	1.27m ~ 2.79m (50in ~ 110in)	1.12m ~ 11.18m (44in ~ 440in)
Lamp Type	230W lamp	230W lamp (190~180W)
Lamp Life	4000 hrs (normal); 3000 hrs (high)	6000hrs (normal) 4000hrs (high)
Keystone Correction	Vertical: $\pm 20^\circ$	Vertical: max $\pm 15^\circ$
Operating Temperature	5°C ~ 35°C (41°F ~ 95°F)	5°C ~ 35°C (41°F ~ 95°F)
Power Supply Voltage	100-240V AC, 50/60Hz	100 ~120V/200 ~ 240V AC, 50/60Hz
Horizontal Scan Rate	15Hz ~ 90kHz	15Hz ~ 90kHz
Vertical Scan Rate	50Hz ~ 85 Hz	50Hz ~ 85 Hz
Computer Compatibility	IBM PC and Compatibles; Apple Macintosh, iMac, and VESA Standards WSXGA+ (1,680 x 1,050), WXGA+ (1,440 x 900), WXGA (1,280 x 800, 1,280 x 768), UXGA (1,600 x 1,200), SXGA+ (1,400 x 1,050), SXGA (1,280 x 1,024), XGA (1,024 x 768), SVGA (800 x 600), VGA (640 x 480)	IBM PC and Compatibles; Apple Macintosh, iMac, and VESA Standards WSXGA+ (1,680 x 1,050), WXGA+ (1,440 x 900), WXGA (1,280 x 800, 1,280 x 768), UXGA (1,600 x 1,200), SXGA+ (1,400 x 1,050), SXGA (1,280 x 1,024), XGA (1,024 x 768), SVGA (800 x 600), VGA (640 x 480)

CONTINUED ON NEXT PAGE

### PROJECTOR SPECIFICATIONS (CONTINUED)

<b>Video Compatibility</b>	NTSC (3.58/4.43), PAL (B/D/G/H/I/M/N), SECAM (B/D/G/K/K1/L), HDTV (720p, 1080i, 1035i), EDTV (480p, 575i), SDTV (480i, 576i)	NTSC (3.58/4.43), PAL (B/D/G/H/I/M/N), SECAM (B/D/G/K/K1/L), HDTV (720p, 1080i, 1035i), EDTV (480p, 575i), SDTV (480i, 576i)
<b>Inputs/Outputs</b>	Computer In (D-sub 15-pin RGB) x 1 Computer In/Out (D-sub 15-pin RGB) selectable x 1 HDMI (Digital RGB) x 1 Composite Video (RCA) x 1 S - Video x 1 Stereo mini-jack In x 1 Audio In (RCA white/red) x 1 Networking LAN (RJ45) x 1 Serial RS-232C x 1	Computer In (D-sub 15-pin RGB) x 2 Computer Out (D-sub 15) x 1 HDMI V.1.3 only for Video x 1 Composite Video (RCA) x 1 S - Video x 1 Networking LAN RJ45 x 1 USB control x 1 Serial RS-232C x 1
<b>Colour</b>	Silver	Silver
<b>Security</b>	Kensington Lock, Security cable bar option, pin code security, remote control operated only	Kensington Lock, Security cable bar option, pin code security, remote control operated only
<b>On-screen Menu</b>	Arabic, Chinese (Simplified), Chinese (Traditional), Danish, Dutch, English, Finnish, French, German, Hungarian, Italian, Japanese, Kazak, Korean, Norwegian, Polish, Portuguese, Portuguese (Brazilian), Romanian, Russian, Spanish, Swedish, Turkish	Arabic, Chinese (Simplified), Chinese (Traditional), Czech, Dutch, English, Finnish, French, German, Greek, Hungarian, Italian, Korean, Norwegian, Polish, Portuguese, Russian, Spanish, Swedish, Turkish
<b>Advanced Features</b>	Long Life Filter – 4000hrs Cable Management Cover Quick Lamp Access Direct power on/off	Filter-less 3D Ready Quick Lamp Access Direct power on/off Cable Management Cover
<b>Packed Contents List</b>	Power cord, computer cable (Dsub 15-Dsub 15), wireless remote, PIN code label, owner's manual (CD-ROM & Quick Start Guide)	Power cord, computer cable (Dsub15-Dsub15), wireless remote, owner's manual (CD-ROM & Quick Start Guide)

### UPGRADE AND ACCESSORY OPTIONS

<b>ActivArena 50 Upgrade Pack</b>	Allows 2 users to work on the ActivBoard simultaneously (includes 2 Teacher ActivPens, 2 Student ActivPens, ActivArena Resources CD, ActivArena paper license, and ActivArena Quick Start Guide)
<b>Wireless Upgrade Pack 100/300</b>	Allows the ActivBoard 300 to connect to the computer wirelessly; includes an ActivHub (2.4 GHz), PSU (power supply unit) and Quick Start Guide
<b>Speakers and Amp Upgrade Pack</b>	Includes two slim line speakers to be inserted in ActivBoard frame; Amplifier (with controls, inputs and outputs), Amp PSU (power supply unit) and Installation Guide (on-site installation); Computer sound is delivered through USB connection
<b>ActivWand 50</b>	Wireless, battery free and extended reach input device for the ActivBoard – 540mm (21.2in) in length; “left click”, cursor and hover, just like a mouse

### WARRANTY AND SUPPORT<sup>†</sup>

<b>ActivBoard, Adjustable Stand</b>	Three-Year Warranty with Three-Year Email and Telephone Support. Additional Two-Year Warranty and Two-Year Email and Telephone Support upon registration.
<b>PRM-30 and PRM-35</b>	Three-Year Projector and Three-Year/3000hr Lamp Warranty with Three-Year Email and Telephone Support.
<b>ActivPen</b>	One-Year Warranty and 90-Day Telephone Support
<b>Support</b>	Online Support for all Promethean Products available from: <a href="http://www.prometheankb.com">www.prometheankb.com</a>

### TECHNICAL DRAWING SPECIFICATIONS

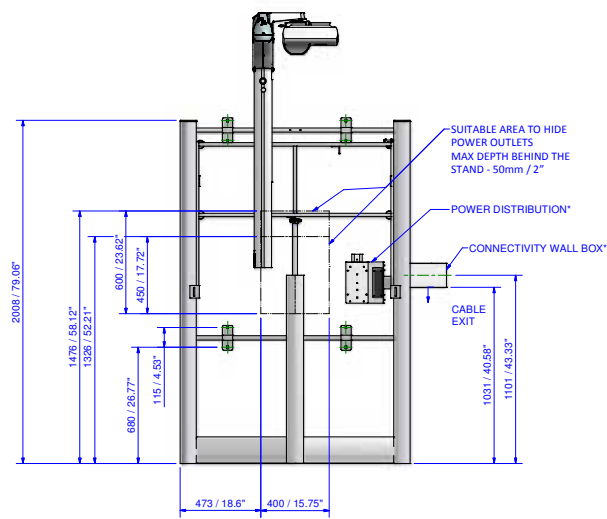
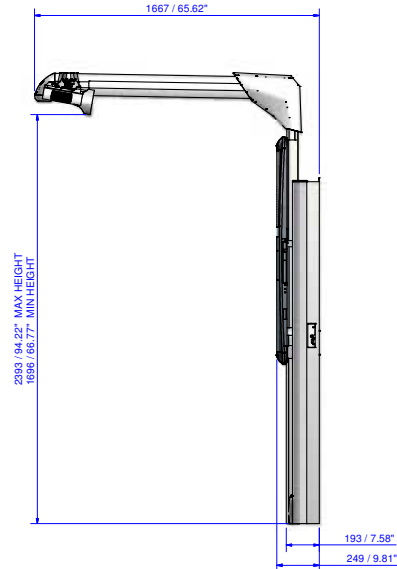
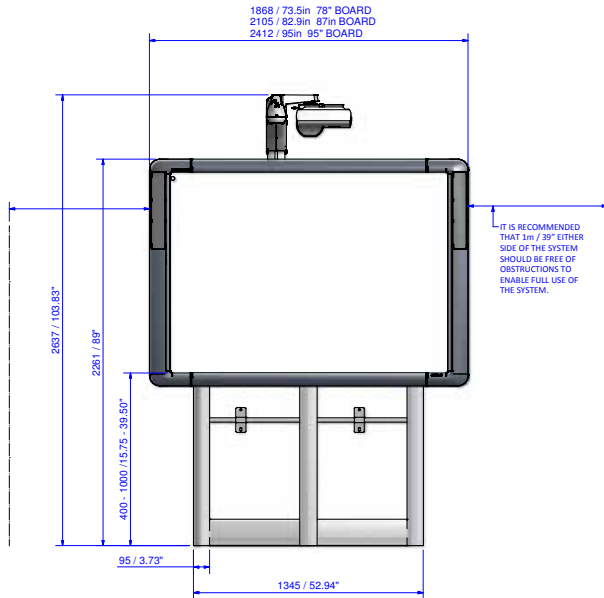

\* CONNECTIVITY BOX AND POWER DISTRIBUTION CAN BE MOUNTED ON EITHER SIDE OF THE SYSTEM.

